

ICOM

INSTRUCTION MANUAL

TRIBAND FM TRANSCEIVER

IC-D1A

IC-D1E

Icom Inc.

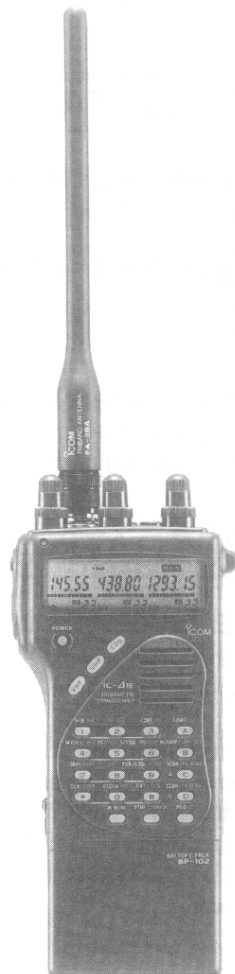

IMPORTANT

READ ALL INSTRUCTIONS carefully and completely before using the transceiver.

SAVE THIS INSTRUCTION MANUAL – This instruction manual contains important safety and operating instructions for the IC-21A/E.

The battery pack and CPU backup battery may require a full charge prior to operation. The transceiver may require CPU resetting after charging. See p. 2 for details.

OPERATING NOTES

BE CAREFUL! When transmitting for a long time with high output power, the rear panel will become hot. If continual, the thermal protection circuit will decrease power.

When using the transceiver with a small-capacity battery pack such as the BP-101 or with manganese dry cell batteries in the BP-100, we recommend operating with low output power. Battery power will be discharged quickly if the transceiver is operated continuously using high output power.

CAUTIONS

NEVER connect the transceiver to an AC outlet or to a power source of more than 15 V DC. These connections will ruin the transceiver.

NEVER connect the transceiver to a power source using reverse polarity. This connection will ruin the transceiver.

NEVER allow children to touch the transceiver.

AVOID using or placing the transceiver in areas with temperatures below -10°C ($+14^{\circ}\text{F}$) or above $+60^{\circ}\text{C}$ ($+140^{\circ}\text{F}$).

AVOID placing the transceiver in direct sunlight.

AVOID the use of chemical agents such as benzine or alcohol when cleaning, as they can damage the transceiver surfaces.

The use of non-Icom battery packschargers may impair transceiver performance and invalidate the warranty.

NOTE: See "Unpacking" on p. 45 for included accessories.

TABLE OF CONTENTS

IMPORTANT	i	7 REPEATER OPERATION	17-18	14 CLOCK AND TIMER OPERATION	31-35
OPERATING NOTES	i	■ Operation	17	■ Auto power-off function	31
CAUTIONS	i	■ Tone information	17	■ CLOCK mode	31
TABLE OF CONTENTS	ii	■ Offset frequency	18	■ Clock operation	32
		■ Subaudible tone	18	■ Power-on timer	33
1 PRE-OPERATION	1			■ Power-off timer	35
2 ACCESSORIES	2	8 MODE ARRANGEMENT	19-20	15 INCREMENTAL TUNING	36
3 BATTERY PACK CHARGING	3-4	■ Mode types	19	■ Incremental tuning	36
4 PANEL DESCRIPTION	5-10	■ Mode arrangement chart	20	■ Incremental tuning selection	36
■ Front and side panels	5	9 MEMORY MODE	21-23	16 PAGER AND CODE SQUELCH	37-40
■ Top panel	6	■ General description	21	■ General description	37
■ Keyboard	7	■ Selecting a memory channel	21	■ Code programming	38
■ Function display	9	■ Programming a memory channel	22	■ Pager operation	39
		■ Transferring memory contents	23	■ Code squelch operation	40
5 SETTING A FREQUENCY	11-13	10 CALL CHANNEL	24	17 OPTIONAL UNIT	
■ Pre-operation	11	■ Calling up a call channel	24	INSTALLATION	41
■ Using a dial	11	■ Transferring call channel contents	24	18 POCKET BEEP AND TONE SQUELCH	42
■ Using the Δ / ∇ keys	12	■ Programming a call channel	24	■ Pocket beep operation	42
■ Using the numeral keys	12	11 SCAN OPERATION	25-28	■ Tone squelch operation	42
■ Setting a tuning step	13	■ Scan types	25	19 TROUBLESHOOTING	43-44
■ Setting a dial select step	13	■ Scan operations	26	■ Troubleshooting	43
		■ Programming scan edges	27	■ Exiting a display	44
6 BASIC OPERATION	14-16	■ Skip channel setting	28	20 OPTIONS	45-46
■ Receiving a signal	14	■ Scan resume condition	28	■ Unpacking	45
■ Setting a squelch level	14	12 PRIORITY WATCH	29	■ Battery packs and carrying cases	45
■ Monitor function	14	■ Priority watch types	29	■ Other options	45
■ Speaker select function	15	■ Priority watch operation	29	21 SPECIFICATIONS	47-48
■ Reduced band operation	15				
■ Power saver	15				
■ Transmitting	16				
■ PTT lock function	16				
■ Low output power	16				

PRE-OPERATION

• First applying power

If [POWER] does not function (the CPU backup battery is empty), the following may be necessary:

While pushing [FUNC], plug-in the wall charger or attach the battery case as illustrated below.

- If correct frequencies appear in the function display, turn power OFF by pushing [POWER] for 1 sec.
- If erroneous information appear in the function display, turn power OFF by pushing [POWER] for 1 sec. and then reset the transceiver. (See right box.)

If your transceiver includes a battery pack, turn power OFF; then, connect the wall charger as described on p. 3. If your transceiver includes a battery case, **NEVER** charge dry cell batteries.

- The CPU backup battery will also be charged.
- See pgs. 3~4 for details on safety and use of a desktop charger.

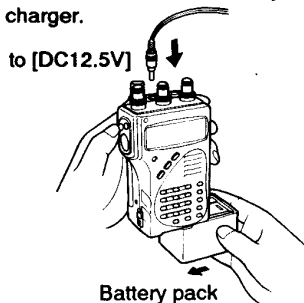

• Resetting the transceiver

When the function display shows erroneous information, the transceiver's CPU may require resetting.

While pushing the [FUNC], [Ⓐ LIGHT] and [⊕ CLR] keys, push [POWER] to turn power ON.

- The function display shows as follows:

VERSION	VHF	UHF	1.2G
U.S.A.	146.01	440.00	1295.00
Asia	146.01	430.00	1295.00
Others	145.00	430.00	1295.00

(UNIT: MHz)

CAUTION: Resetting the CPU will clear all setting contents such as memory channels, time, etc.

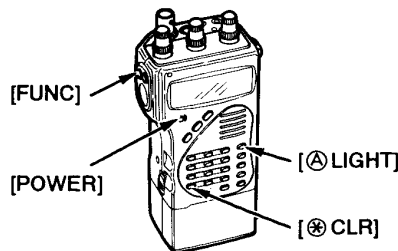

• Connecting the antenna

Insert the supplied antenna into the antenna connector and rotate the antenna as shown in the diagram below.

KEEP the jack cover attached when jacks are not in use to avoid bad contacts.

CAUTION: Transmitting without an antenna may damage the transceiver.

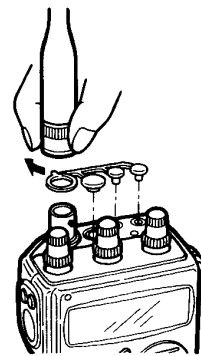

• Battery pack removal

Push the battery pack release button upwards, then slide the battery pack to the right with the transceiver facing you.

To attach the battery pack, slide it until hearing a click.

NOTE: Minimal current drain to the lithium backup battery and CPU will result in exhaustion of an attached battery pack or case during long periods of storage.

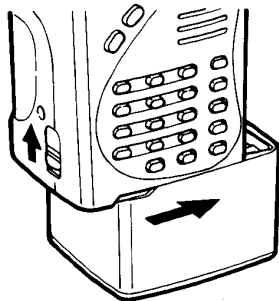

• Battery case

Some versions come with the BP-100 BATTERY CASE for using the transceiver with dry cell or NiCd batteries.

1. Push the end of the cover release plate, then, open the cover while pushing the cover downwards.

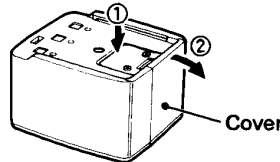

2. Install six AA (R6) type batteries. Be careful of the polarity of the batteries.

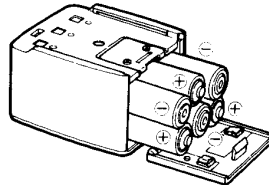

3. Attach the cover to the bottom of the case; then, push it in place.

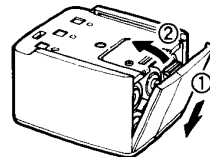

• Belt clip

The belt clip allows you to attach the transceiver to your belt.

Remove the plastic screws and use the metal screws to attach the belt clip.

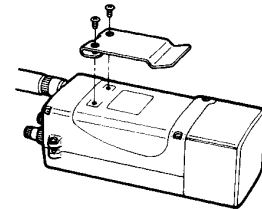

• Handstrap

The handstrap is convenient for carrying the transceiver.

1. Insert the handstrap using a pointed instrument.
2. Put one end through the other end's loop, then, pull it to tighten.

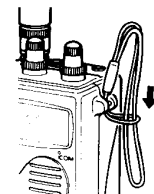
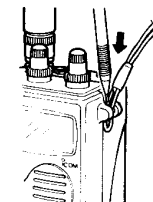

BATTERY PACK CHARGING

• Regular charging

Connect a wall charger to the [DC12.5V] jack.

NEVER charge the BP-100 with dry cell batteries.

to
[DC12.5V]

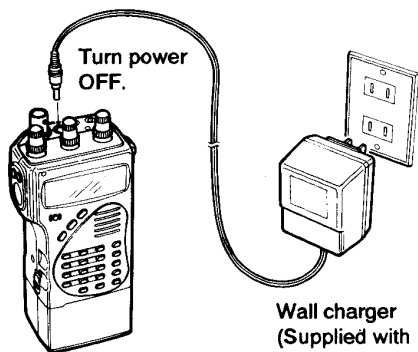

BP-101, BP-102 or
NiCd batteries with
BP-100

Wall charger
(Supplied with the
transceiver
except for the
Asia version.)

BATTERY PACK OR CASE	BP-101	BP-102	BP-100 (NiCd)
APPROX. CHARGING PERIOD	15 hrs.	15 hrs.	12~20 hrs.

• Rapid charging with the optional BC-79

Insert the AD-27 BATTERY PACK ADAPTER into the BC-79 DESKTOP CHARGER. Then insert the BP-101~BP-103 into the charging slot of the BC-79.

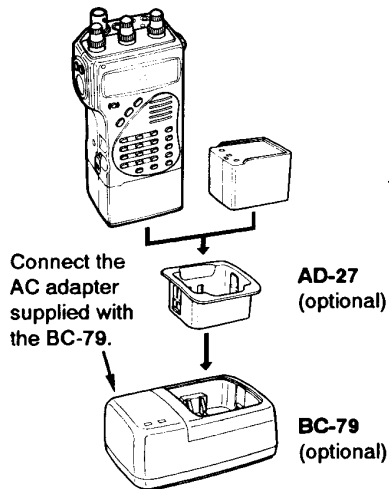

Connect the
AC adapter
supplied with
the BC-79.

AD-27
(optional)

BC-79
(optional)

BATTERY PACK	BP-101	BP-102	BP-103
APPROX. CHARGING PERIOD	1 hr.	1.5 hrs.	1.5 hrs.

• Charging with optional charger or cables

CP-13 (optional)

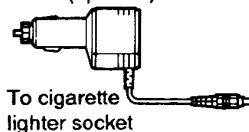

To cigarette
lighter socket

OPC-288 (optional)

white ⊕

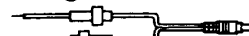

black ⊖

To 12~15 V DC
power source

BC-77A/D/E/V

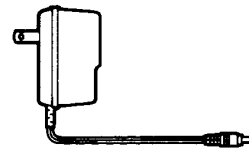

to
[DC12.5V]



BP-101,
BP-102 or
NiCd batteries
with BP-100

To charge the BP-103, see the right page.

NEVER connect the above charger or cable when dry cell batteries are used with the BP-100.

• Charging period: Approx. 12~20 hrs.

• Charging without the transceiver

To charge the battery pack separately from the transceiver, the AD-22 BATTERY CHARGE ADAPTER is available from Icom.

NEVER charge dry cell batteries via the BP-100 BATTERY CASE.

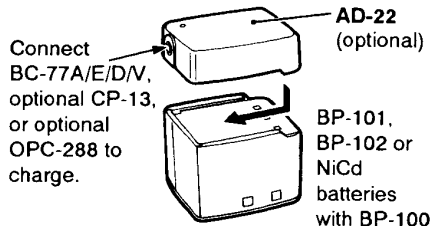

• Charging period: Approx. 12-20 hrs.

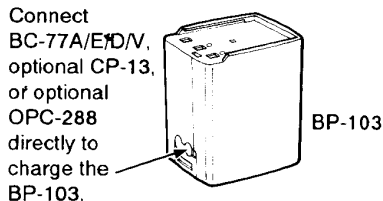

• Charging period: Approx. 20 hrs.

• Charging notes

NEVER attempt to charge dry cell batteries.

Connect one charger. **NEVER** connect two or more chargers at the same time.

Be sure to turn the transceiver power OFF during charging.

Charging may not occur in extreme cold (under 0°C; +32°F) or extreme heat (over +40°C; +104°F).

• Using your battery wisely

Overcharging and complete discharging may shorten the life of a battery.

Recharging can usually be performed 300 times, but battery life can be lengthened to about 500 recharges as follows:

1. Avoid overcharging. The charging period should be less than 48 hours.
2. Use the battery until it is almost completely discharged under normal conditions. We recommend battery charging as soon as transmitting becomes impossible.

• Operating period

The listed operating periods at right are calculated values for your reference and are based on the following conditions:

1. Transmitting (High) :
Receiving : Standby =
1 min. : 1 min. : 8 min.
2. Used as a monoband transceiver.

BATTERY	OUTPUT VOLTAGE	APPROX. OPERATING PERIOD*		
		VHF BAND	UHF BAND	1.2G BAND
BP-101	7.2 V	6 h.	4 h. 20 m.	5 h. 20 m.
BP-102	7.2 V	10 h. 20 m.	7 h. 20 m.	9 h. 20 m.
BP-103	12.0 V	3 h. 40 m.	3 h.	4 h. 40 m.

*Operating period varies depending on operating conditions such as output power, temperature, etc.

4

PANEL DESCRIPTION

■ Front and side panels

FUNCTION SWITCH [FUNC]

Activates secondary functions (written in blue). While pushing [FUNC], all switches activate secondary functions. (pgs. 7, 8)

Activates the dial select function when VFO mode has been selected in the desired band. (p. 13)

SQUELCH SWITCH [S] (p. 14)

Shows the squelch level and activates all [DIAL]s for squelch setting.

PTT SWITCH [PTT] (p. 16)

Push and hold to transmit; release to receive.

BATTERY PACK RELEASE BUTTON

(p. 2)
Opens the latch for battery pack removal when pushed upwards. Slide battery pack to the right for removal.

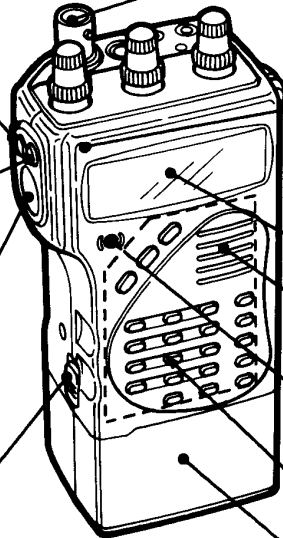

ANTENNA CONNECTOR (p. 1)

Connects the supplied flexible antenna.

TRANSMIT/RECEIVE INDICATOR

(pgs. 14, 16)

Lights up in green when a squelch opens; lights up in red when transmitting; lights up in orange when transmitting on one band while another band's (1 or 2) squelch is open.

FUNCTION DISPLAY (pgs. 9, 10)

SPEAKER/MICROPHONE

POWER KEY [POWER] (p. 11)

Turns the power ON and OFF when pushed for 1 sec. or longer.

KEYBOARD (pgs. 7, 8)

BATTERY PACK/CASE (pgs. 1-4)

■ Top panel

EXTERNAL DC POWER JACK

[DC12.5V]

Connects a charger for charging the battery pack. (p. 3)

Allows operation with a 12.5 V DC power source using the optional cables, CP-13 or OPC-288. (p. 46)

Be careful of overcharging!

Operation with an external DC power source simultaneously charges the battery pack.

VHF VOLUME CONTROL [VHF VOL]

Adjusts the VHF band audio output level.

VHF DIAL [VHF DIAL]

Selects the VHF band operating frequency, memory channel, SET mode contents and the scanning direction.

UHF VOLUME CONTROL [UHF VOL]

Adjusts the UHF band audio output level.

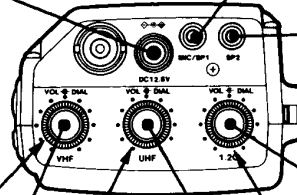

EXTERNAL SPEAKER/MICROPHONE JACK [MIC/SP1]

Connects an optional speaker-microphone or headset, if desired. (p. 46)

Audio of the speaker-selected bands are output. (pgs. 9, 15)

EXTERNAL SPEAKER JACK [SP2]

Connects an optional earphone or external speaker, if desired. (p. 46) Audio of the speaker-off bands are output. (pgs. 9, 15)

1.2 GHz DIAL [1.2G DIAL]

Selects the 1.2 GHz band operating frequency, memory channel, SET mode contents and the scanning direction.

1.2 GHz VOLUME CONTROL [1.2G VOL]

Adjusts the 1.2 GHz band audio output level.

UHF DIAL [UHF DIAL]

Selects the UHF band operating frequency, memory channel, SET mode contents and the scanning direction.

4 PANEL DESCRIPTION

Keyboard

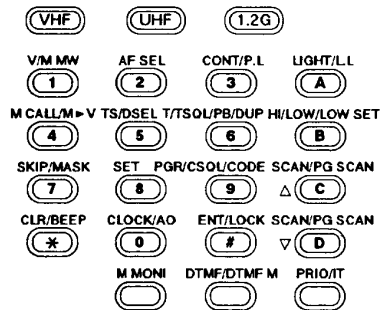

Primary function Secondary function

V/M MW

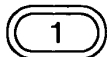

PRIMARY FUNCTION

(written in white):

Activated by pushing the key only.

SECONDARY FUNCTION

(written in blue):

Activated by pushing the key while holding the [FUNC] switch on the side panel.

KEY	PRIMARY FUNCTION	SECONDARY FUNCTION
VHF	Selects the 144 MHz band as the MAIN band. (p. 11) Emits a 1750 Hz tone while transmitting. (IC-Δ1E only) (p. 17)	Activates or deactivates the 144 MHz band. (p. 15)
UHF	Selects the 430 (440) MHz band as the MAIN band. (p. 11)	Activates or deactivates the 430 (440) MHz band. (p. 15)
1.2G	Selects the 1.2 GHz band as the MAIN band. (p. 11)	Activates or deactivates the 1.2 GHz band. (p. 15)
LIGHT/L.L A	Turns ON the display and keyboard back-lighting for 5 sec. (p. 11) Emits DTMF digit A while transmitting. (p. 17)	Turns ON the display and keyboard backlighting continuously. (p. 11)
HI/LOW/LOW SET B	Selects high or low output power. (p. 16) Emits DTMF digit B while transmitting. (p. 17)	Selects low output power for the 144 MHz and 430 (440) MHz band in 3 levels. Use this function together with a [DIAL]. (p. 16)
SCAN/PG SCAN Δ C SCAN/PG SCAN ▽ D	Changes the frequency or memory channel. Starts the full scan or memory scan when pushed and held. (pgs. 12, 26) Emits DTMF digit C or D while transmitting. (p. 17)	Starts the programmed scan or memory skip scan. (p. 26)
M MONI	Opens the squelch of the MAIN band. (pgs. 16, 17)	Opens the squelch of the MAIN band. (pgs. 16, 17)
DTMF/DTMF M	Emits the programmed DTMF memory code. (p. 30)	Enters DTMF MEMORY mode to program the DTMF memory. (p. 30)
PRIO/IT	Starts the priority watch. (p. 29)	Activates the incremental tuning. (p. 36)

KEY	PRIMARY FUNCTION	SECONDARY FUNCTION	OTHER FUNCTION
V/M MW (1)	Selects VFO or MEMORY mode. (pgs. 11, 21)	Writes the VFO contents into the memory channel or call channel when pushed and held. (pgs. 22, 24)	<p style="text-align: right;">ENT/LOCK (#): After pushing (#): Digit keys are activated for frequency input. (p. 12)</p> <p style="text-align: right;">While transmitting: Sends a DTMF digit. (p. 17)</p>
AF SEL (2)	No primary function.	Selects the speaker output. (p. 15)	
CONT/P L (3)	Selects display contrast from 4 levels. (p. 11)	Turns the PTT lock function ON and OFF. (p. 16)	
M CALL M-V (4)	Calls up the call channel. (p. 24)	Transfers the contents in the selected memory or call channel into the VFO. (pgs. 23, 24)	
TS/DBEL (5)	Selects the tuning step. Use the switch together with a [DIAL]. (p. 13)	Selects the dial select step from among 100 kHz, 1 MHz, or memory channel changing. (10 MHz is available for the 1.2 GHz band) (p. 13)	
T.TSOL/PB/DUP (6)	Turns ON the following optional functions in this sequence: subaudible tone encoder* → pocket beep → tone squelch → non-tone operation. (pgs. 17, 42)	Selects the duplex direction in this sequence: - duplex → + duplex → simplex. (p. 17)	
SKIP/MASK (7)	Sets the selected memory channel as a skip memory channel. (p. 28)	Recalls the previously set power-on or power-off time. Sets the selected code channel for "receive inhibit." (pgs. 33, 35, 38)	
SET (8)	No primary function.	Selects SET mode. (p. 20)	
PGR/CSOL/CODE (9)	Turns ON the following optional functions in this sequence: pager → code squelch → non-selective calling operation. (pgs. 39, 40)	Used for programming the code channel for pager and code squelch. (p. 38)	
CLOCK/IAO (0)	Enters CLOCK mode. (p. 31)	Selects the auto power-off period. Use this function together with a [DIAL]. (p. 31)	
CLR/BEEP (X)	Clears the entered digit before input. (p. 12) Exits SET and CLOCK modes. (pgs. 20, 31)	Turns the beep function ON and OFF. (p. 11)	
ENT/LOCK (#)	Sets the keyboard for numeral use. (p. 12)	Turns the lock function ON and OFF. (p. 11)	

* Built-in to the U.S.A. version

4 PANEL DESCRIPTION

■ Function display

MAIN BAND INDICATOR

Appears above the frequency readout of the MAIN band. The MAIN band can be used for transmitting and receiving; other bands can be used for receiving only.

FUNCTION INDICATOR

Appears while the [FUNC] switch is pushed.

FREQUENCY READOUTS

Show the operating frequency, SET mode contents or time.

SPEAKER INDICATOR (p. 15)

Appears below the frequency readout when the internal speaker and [SP1] jack are selected; disappears when the [SP2] jack is selected.

MEMORY INDICATOR (p. 21)

Appears when MEMORY mode is selected.

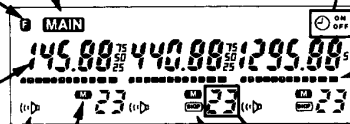

The above display is for descriptive purposes only. Some indicators do not appear simultaneously.

TIMER INDICATOR (pgs. 31~35)

Appears when the clock is displayed or the timer function is in use.

- "ON" appears when the power-on timer is in use.
- "OFF" appears when the power-off timer is in use.

S/R/F INDICATORS

Show the relative signal strength when receiving. (p. 14)

Show the selected output power when transmitting. (p. 16)

Show the squelch level (4 levels) when setting squelch. (p. 14)

MEMORY CHANNEL READOUT (p. 21)

Shows the memory channel number.

- A large "L" appears when the lock function is in use. (p. 11)
- A large "C" appears when a call channel is selected. (p. 24)

SKIP INDICATOR (p. 28)

Appears when the displayed memory channel is set as a skip channel.

DUPLEX INDICATOR (p. 17)

“-DUP” or “DUP” appears when semi-duplex is selected on the MAIN band for repeater operation.

LOW POWER INDICATOR (p. 16)

Appears when low power is selected on the MAIN band.

CLOCK INDICATION (p. 32)

Shows the current time.

STONE INDICATORS

“T” appears when the subaudible tone encoder* is turned ON. (p. 17)

* Optional except for the U.S.A. version.

“T SQL” appears when the optional tone squelch function is activated. (p. 42)

“T SQL [•••]” appears when the optional pocket beep function is activated. (p.42)

PAGER INDICATOR (p. 39)

“P” appears instead of the 100 MHz digit when the pager function is activated.

SQUELCH INDICATOR (p. 14)

Appears while the [S] switch is pushed.

PTT LOCK INDICATOR (p. 16)

Appears when the PTT lock function is activated.

INCREMENTAL TUNING INDICATOR (p. 36)

Appears when the incremental tuning function for the 1.2 GHz band is activated.

CODE SQUELCH INDICATOR (p. 40)

“C” appears instead of the 100 MHz digit when the code squelch function is activated.

PRIORITY WATCH INDICATOR (p. 29)

Appears when the priority watch function is activated; flashes when the watch is paused.

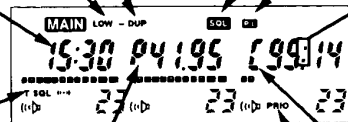

The above display is for descriptive purposes only. Some indicators do not appear simultaneously.

■ Pre-operation

• Turning power ON

Push [POWER] for 1 sec. to turn the transceiver power ON and OFF.

• Selecting VFO mode

Push the desired band switch: [VHF], [UHF] or [1.2G], then push [①V/M] once or twice to select VFO mode.

- Be sure "M" or large "C" is not indicated on the desired band.
- See p. 19 for mode construction details.

NOTE: When the lock function is activated, the keyboard and [DIAL]s cannot be used, and the mode cannot be changed.

• Lock function

To prevent accidental frequency changes and unnecessary function access, a key lock function is available.

- While pushing [FUNC], push [ⓉLOCK] to turn the lock function ON or OFF.
 - "L" appears when the lock function is activated.

• Display contrast

Display contrast can be changed through 4 levels.

- Each push of [③CONT] changes the function display contrast to 1 of 4 levels.

• Display lighting

The display and keyboard lighting have a 5 sec. timer for night operation.

- Push [ⒶLIGHT] to turn ON the lighting for 5 sec; push [ⒶLIGHT] while pushing [FUNC] for continuous lighting.
 - Push [ⒶLIGHT] again to turn the lighting OFF.

NOTE: Continuous lighting remains activated even when the power is turned OFF and ON again.

• Beep tones

The transceiver emits a beep tone each time a switch is pushed. High or low tones are emitted for correct or incorrect operations, respectively. For silent operation, beep tones can be turned OFF.

- While pushing [FUNC], push [ⓈBEEP] to turn the beep tones ON or OFF.

■ Using a dial

- 1) Rotate the desired band [DIAL] to set the frequency.
 - If VFO mode is not selected, push the desired band switch: [VHF], [UHF] or [1.2G], then, select VFO mode.
 - See p. 13 for setting the tuning step details.
- 2) To change the frequency quickly, rotate the desired band [DIAL] in VFO mode while pushing [FUNC].
 - See p. 13 for setting a dial select step details.

■ Using the Δ / ∇ keys

- 1) Push the desired band switch: [VHF], [UHF] or [1.2G].
 - Select VFO mode if another mode has been selected.
- 2) Push [$\odot\Delta$] or [$\odot\nabla$] to change the frequency.
 - The frequency changes according to the tuning step. (p. 13)
 - Pushing the key for more than 0.5 sec. will activate full scan.
 - If the scan is started, push [$\odot\Delta$] or [$\odot\nabla$] again to stop.

■ Using the numeral keys

- 1) Push the desired band switch: [VHF], [UHF] or [1.2G].
 - Select VFO mode if another mode has been selected.
- 2) Push [$\#$ ENT] to activate the keyboard for numeral input.
- 3) Push 4 appropriate digit keys to input a frequency.
 - When a wrong digit is input, push [\otimes CLR] to clear the input, then start again from step 2.
 - "0," "2," "5," or "7" are acceptable for the 1 kHz digits of the 144 MHz/430 (440) MHz bands or for the 10 kHz digits of the 1.2 GHz band, according to the selected tuning step.

[EXAMPLE]: Setting the frequency to 145.360 MHz.

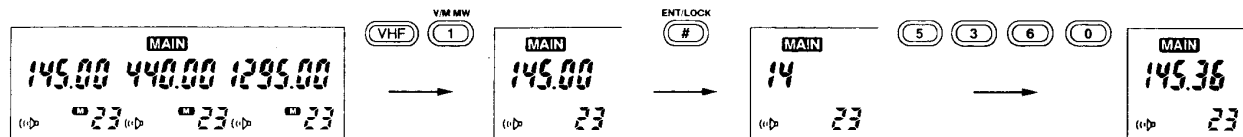

[EXAMPLE]: Setting the frequency to 1295.325 MHz. (When the 25 kHz tuning step is selected on the 1.2 GHz band.)

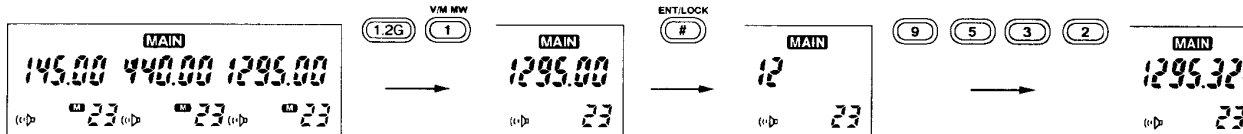

5 SETTING A FREQUENCY

■ Setting a tuning step

The [DIAL]s or the Δ / ∇ keys change the frequency in step increments. For your convenience, the tuning step should be set to the repeater tuning step in your area. Separate tuning steps can be specified for each band.

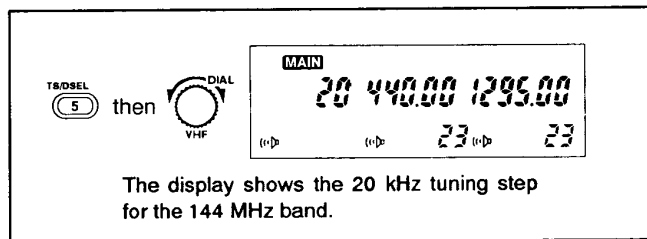

- 1) Push the desired band switch: [VHF], [UHF] or [1.2G].
- 2) Push [① V/M] to select VFO mode if another mode has been selected.
- 3) Push [⑥ TS] to display the previously selected tuning step as shown above.
- 4) Rotate the MAIN band [DIAL] to set the tuning step.
- 5) Push [⊗ CLR] to return to VFO mode.

■ Setting a dial select step

In VFO mode, while pushing [FUNC], [DIAL] changes the frequency in 100 kHz, 1 MHz or 10 MHz* increments or changes the memory channel according to the selected step increment.

* 1.2 GHz band only.

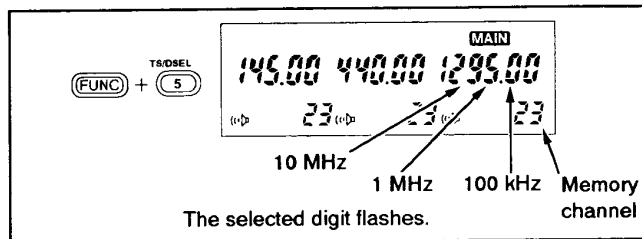

- 1) Push the desired band switch: [VHF], [UHF] or [1.2G].
- 2) Push [① V/M] to select VFO mode if another mode has been selected.
- 3) While pushing [FUNC], push [⑤ DSEL] several times to select the desired increment.
 - The selected digit or memory channel number flashes while pushing [FUNC].

NOTE: When incremental tuning is in use, this function cannot be used in the 1.2 GHz band. (p. 36)

6 BASIC OPERATION

■ Speaker select function

Audio for each of the 3 bands can be turned ON or OFF using the speaker select function. Audio of the speaker-selected band is output from the internal speaker or [SP1]. Audio of the non-selected band is output from [SP2].

- 1) Push the desired band switch: [VHF], [UHF] or [1.2G].
- 2) While pushing [FUNC], push [ⓂAF SEL] to turn the speaker indicator ON or OFF.
 - “(Ⓜ)” appears under the frequency readout of the speaker-selected band.

NOTE: Audio of the non-selected band, which “(Ⓜ)” is not indicated, cannot be heard when an optional ear-phone, etc. is not connected to the [SP2] jack.

■ Reduced band operation



Any band that is not necessary for operation can be turned OFF. Reduced band operation conserves battery power by turning OFF the circuit of the band not displayed.

- While pushing [FUNC], push the desired band switch: [VHF], [UHF] or [1.2G], to turn the band ON or OFF.

■ Power saver

USING SET MODE

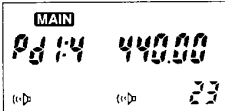
The power saver function reduces the current drain to conserve battery power. The duty cycle of the power saver can be selected and the function can be turned ON or OFF.

		
Standby 125 msec. Circuit off 500 msec.	125 msec. 2 sec.	Power saver is turned OFF.
Separate setting for each band.		

- 1) Push the desired band switch: [VHF], [UHF] or [1.2G].
 - Select VFO mode if another mode has been selected.
- 2) While pushing [FUNC], push [ⓂSET] to enter SET mode.
 - Refer to p. 20 for SET mode details.
- 3) Push [Ⓜ△] or [Ⓜ▽] until “Pd” appears as shown above.
- 4) Rotate the MAIN band [DIAL] to select the desired duty cycle or to turn the function OFF.
- 5) Push [ⓂCLR] to set the value and to exit SET mode.

■ Operation

A repeater amplifies a received signal and transmits it at a different frequency. When using a repeater, the transmit frequency is shifted from the receive frequency by the offset frequency. It is convenient to program repeater information into a memory channel. (p. 22)

- 1) Push the desired band switch: [VHF], [UHF] or [1.2G].
- 2) Set the receive frequency (repeater output frequency). (pgs. 11~13)
- 3) While pushing [FUNC], push [Ⓢ DUP] to select – duplex or push it again for + duplex.
 - “– DUP” or “+ DUP” appears to indicate the transmit frequency for minus shift or plus shift respectively.
- 4) Push and hold [PTT] to transmit.
 - The displayed frequency automatically changes to the transmit frequency (repeater input frequency).
 - When the repeater requires a tone, see section at right.
 - If “o.FF” appears, confirm the offset frequency. (p. 18)
- 5) Release [PTT] to receive.
- 6) Push and hold [M MONI] to check whether the other station's transmit signal can be directly received or not.

■ Tone information

SUBAUDIBLE TONE

(An optional UT-70 or UT-71 is necessary for non-U.S.A. versions.)

- 1) Push [Ⓢ T/SQL/PB] several times to turn ON the subaudible tone encoder until only “T” appears.
 - To set the subaudible tone frequency, see “Subaudible tone” on the page at right.
- 2) Push [Ⓢ T/SQL/PB] several times until “T” disappears to turn OFF the subaudible tone encoder.

DTMF TONES

While pushing [PTT], push the desired digit key to transmit DTMF tones.

- The transceiver has 4 DTMF memory channels. See p. 30 for details.

1750 Hz TONE (IC-Δ1E only)

While pushing [PTT], push and hold [VHF] for 1~2 sec. to transmit a 1750 Hz tone call signal.

Offset frequency USING SET MODE

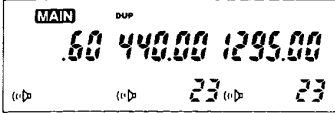

The display shows an offset frequency of 0.6 MHz (600 kHz) for the 144 MHz band.

Separate setting for each band.

- 1) Enter SET mode:
 - Push the desired band switch: [VHF], [UHF] or [1.2G].
 - Push [①V/M] to select VFO mode if another mode has been selected.
 - While pushing [FUNC], push [ⓈSET] to enter SET mode.

- 2) Push [Ⓢ△] or [Ⓢ▽] until "DUP" appears as shown above.
 - Refer to p. 20 for SET mode details.

- 3) Rotate the MAIN band [DIAL] to set the desired offset frequency.
 - The offset frequency changes in the selected tuning step. (p.13)
 - For quick selection, rotate the MAIN band [DIAL] while pushing [FUNC].

- 4) Push [ⓈCLR] to set the value and to exit SET mode.

Subaudible tone USING SET MODE

(An optional UT-70 or UT-71 is necessary for non-U.S.A. versions.)

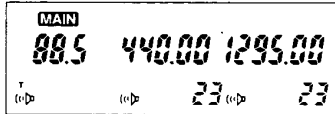

The display shows an 88.5 Hz subaudible tone frequency for the 144 MHz band.

Separate setting for each band.

- 1) Enter SET mode:
 - Push the desired band switch: [VHF], [UHF] or [1.2G].
 - Push [①V/M] to select VFO mode if another mode has been selected.
 - While pushing [FUNC], push [ⓈSET] to enter SET mode.

- 2) Push [Ⓢ△] or [Ⓢ▽] until "T" appears as shown above.
 - Refer to p. 20 for SET mode details.

- 3) Rotate the MAIN band [DIAL] to select the desired subaudible tone frequency.

- 4) Push [ⓈCLR] to set the value and to exit SET mode.

67.0	97.4	136.5	192.8
71.9	100.0	141.3	203.5
74.4	103.5	146.2	210.7
77.0	107.2	151.4	218.1
79.7	110.9	156.7	225.7
82.5	114.8	162.2	233.6
85.4	118.8	167.9	241.8
88.5	123.0	173.8	250.3
91.5	127.3	179.9	
94.8	131.8	186.2	

(Unit: Hz)

Mode types

VFO MODE

(frequency setting) (p. 11)

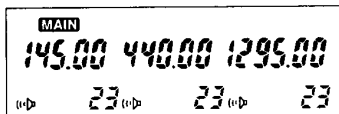

"M" or large "C" does not appear.

Used for frequency setting and normal operations over the entire 144 MHz, 430 (440) MHz and 1.2 GHz bands.

- VFO is an abbreviation for Variable Frequency Oscillator.

SET MODE (p. 20)

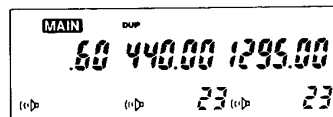

SET mode contents appears.

Used for programming infrequently changed settings. The 144 MHz, 430 (440) MHz and 1.2 GHz bands have separate SET modes.

MEMORY MODE (p. 21)

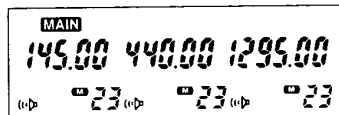

"M" appears.

Used for operating the transceiver using memory channel contents. Each band has 25 memory channels. A total of 75 memory channels are available.

DTMF MEMORY MODE (p. 30)

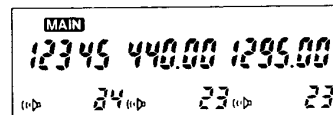

DTMF memory channel appears.

Used for programming DTMF codes. 4 DTMF memory channels are available and each DTMF memory channel has up to 15 digits of programming capability.

CALL CHANNEL (p. 24)

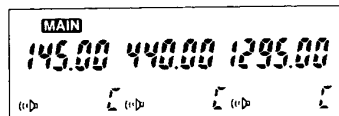

Large "C" appears.

Used for operating the transceiver on a programmed call channel. The 144 MHz, 430 (440) MHz and 1.2 GHz bands have their own separate call channel.

CLOCK MODE (p. 31)

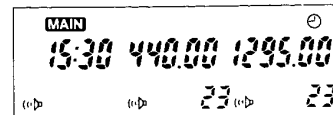

Clock or timer appears.

Used for indicating or setting the clock time, power-on timer and power-off timer.

Mode arrangement chart

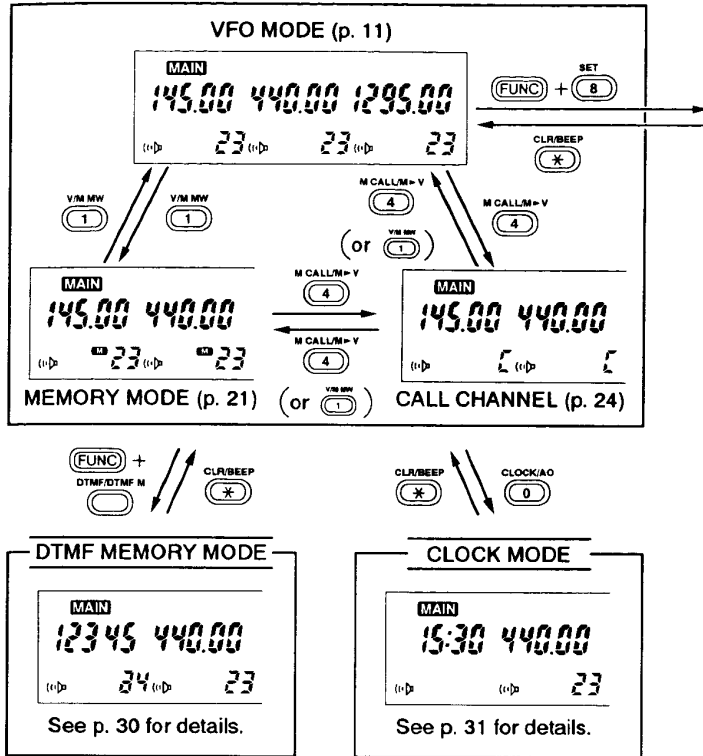

Although the following chart refers mostly to the 144 MHz band, the transceiver has the same mode arrangements in the 430 (440) MHz and 1.2 GHz bands.

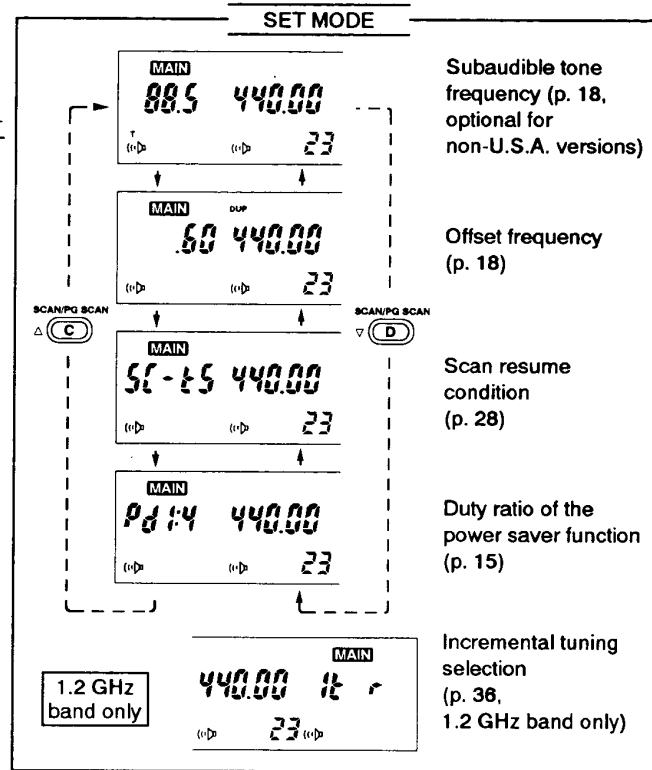

General description

The transceiver has 23 memory channels (plus 2 scan edge memory channels) on each band for storage of often-used frequencies. You can program the following data into each memory channel separately.

- Operating frequency
- Squelch level setting
- Duplex direction (DUP or – DUP)
- Offset frequency
- Subaudible tone frequency*¹
- Subaudible tone encoder ON/OFF*¹
- Tone squelch ON/OFF*²
- Skip information*³

*¹ An optional UT-70 TONE SQUELCH UNIT or UT-71 PROGRAMMABLE TONE ENCODER UNIT is necessary for non-U.S.A. versions.

*² An optional UT-70 TONE SQUELCH UNIT is necessary.

*³ Except for the scan edge memory channels.

Selecting a memory channel

- 1) Push the desired band switch: [VHF], [UHF] or [1.2G].
- 2) Push [Ⓜ V/M] to select MEMORY mode.
 - “M” appears.
- 3) Rotate the MAIN band [DIAL] to select the desired memory channel.
 - Pushing [Ⓞ Δ] or [Ⓞ ▽] also selects memory channels.
 - Pushing [Ⓞ Δ] or [Ⓞ ▽] for more than 0.5 sec. will activate memory scan. If the scan is started, push [Ⓞ Δ] or [Ⓞ ▽] again to stop the scan.
 - Memory channels “A” and “b” are scan edge channels. (p. 27)
- 4) To return to VFO mode, push [Ⓜ V/M].

EXAMPLE: Selecting memory channel 20 on the 430 (440) MHz band.

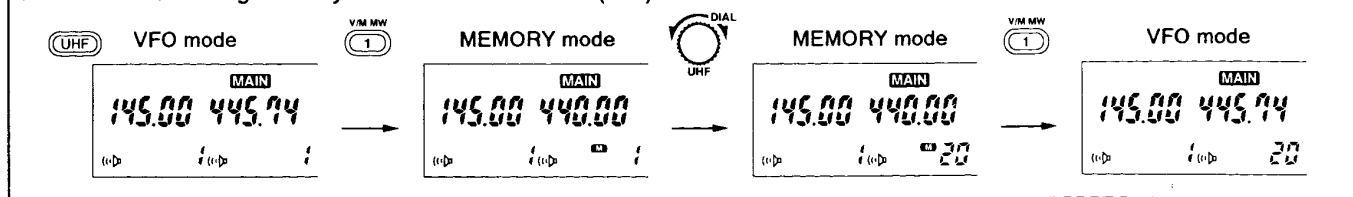

■ Programming a memory channel

VFO mode settings, including the SET mode contents such as subaudible tone frequency, etc., are programmed into a memory channel.

- 1) Push the desired band switch: [VHF], [UHF] or [1.2G].
- 2) Select the memory channel to be programmed:
 - Push [① V/M] to select MEMORY mode. ("M" appears.)
 - Rotate the MAIN band [DIAL] to select the memory channel.

- 3) Set the desired frequency in VFO mode:
 - Push [① V/M] to select VFO mode.
 - Set the desired frequency using the keyboard or [DIAL].
 - Set other data (e.g. duplex information, squelch level), if required.
- 4) While pushing [FUNC], push and hold [① MW] to program.
 - If the beep tone is ON, 3 beeps alert you that the VFO contents, including the setting of squelch level, duplex information, subaudible tone frequency, etc., are programmed.

EXAMPLE: Programming 145.375 MHz into memory channel 20.

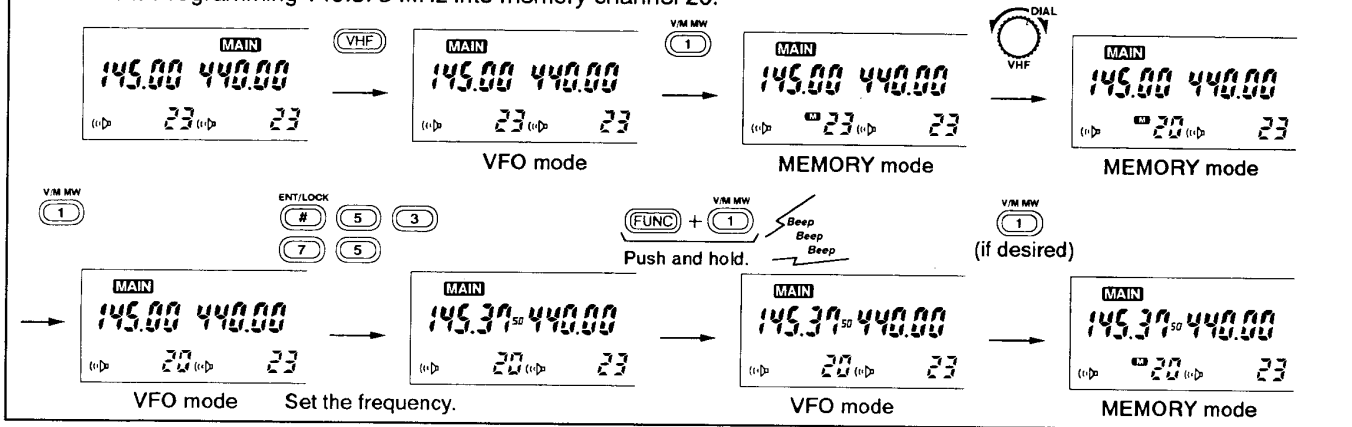

9 MEMORY MODE

■ Transferring memory contents

This function transfers the memory channel contents into a VFO. This is useful for searching for signals around a memory channel frequency and for recalling the offset frequency, subaudible tone frequency, squelch level, etc. which are programmed in the memory channel.

1) Push the desired band switch: [VHF], [UHF] or [1.2G].

2) Select the memory channel to be transferred:

- Push [① V/M] to select MEMORY mode. ("M" appears.)
- Rotate the MAIN band [DIAL] to select the memory channel.

3) While pushing [FUNC], push and hold [④ V ▶ M].

- "M" disappears as VFO mode is automatically selected.
- If the beep tone is ON, 3 beeps alert you that the memory channel contents, including the setting of squelch level, duplex information, subaudible tone frequency, etc., are transferred.

EXAMPLE: Transferring the contents of 144 MHz band memory channel 20 into the VFO.

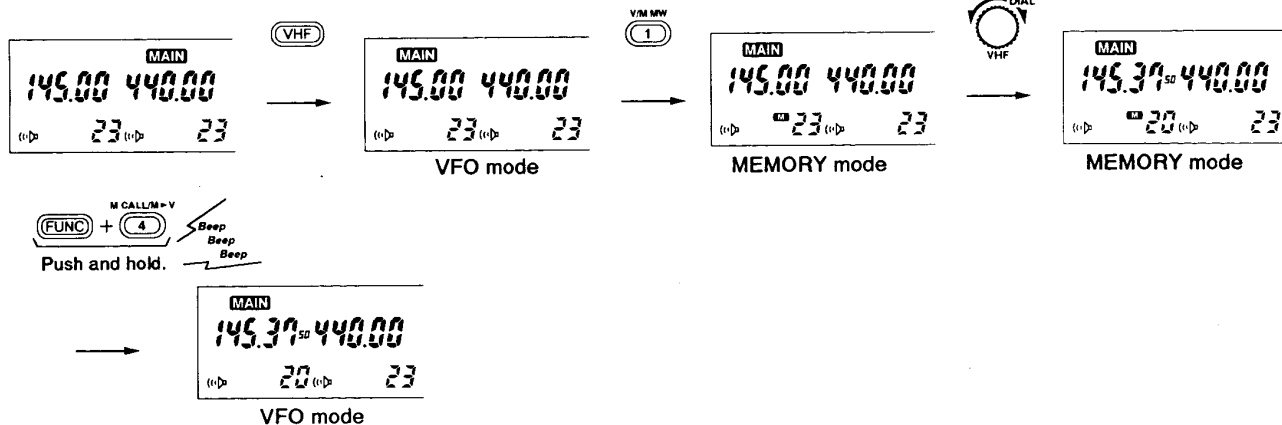

■ Calling up a call channel

A one-touch access call channel is provided on each band. Use the call channel for storage of a most-often-used frequency.

- 1) Push the desired band switch: [VHF], [UHF] or [1.2G].
- 2) Push [④ M CALL] to select the call channel.
 - "C" appears.
- 3) To return to the previous mode, push [④ M CALL] again.

■ Transferring call channel contents

- 1) Push the desired band switch: [VHF], [UHF] or [1.2G].
- 2) Push [④ M CALL] to select the call channel.
 - "C" appears.
- 3) While pushing [FUNC], push and hold [④ V ► M].
 - "C" disappears as VFO mode is automatically selected.
 - If the beep tone is ON, 3 beeps alert you that the call channel contents, including the setting of squelch level, duplex information, subaudible tone frequency, etc., are transferred.

■ Programming a call channel

As well as an operating frequency, squelch level, duplex information and subaudible tone information* (tone encoder or tone squelch ON/OFF and its frequency) can be programmed into a call channel.

* Optional function depending on versions.

- 1) Push the desired band switch: [VHF], [UHF] or [1.2G].
- 2) Set the desired frequency in VFO mode:
 - Push [① V/M] to select VFO mode.
 - Set the desired frequency using the keyboard or [DIAL].
 - Set other data (e.g. duplex information, squelch level), if required.
- 3) Push [④ M CALL] to select the call channel.
 - "C" appears.
- 4) While pushing [FUNC], push and hold [① MW] to program.
 - If the beep tone is ON, 3 beeps alert you that the VFO contents, including the setting of squelch level, duplex information, subaudible tone frequency, etc., are programmed.

11 SCAN OPERATION

Scan types

Scanning searches signals which someone transmits automatically and makes it easier to locate a new station for contact or listening purposes.

Each band has 4 scan types with skip functions and 2 resume conditions to suit your needs. Scans on the 3 bands can be operated separately or simultaneously.

FULL SCAN

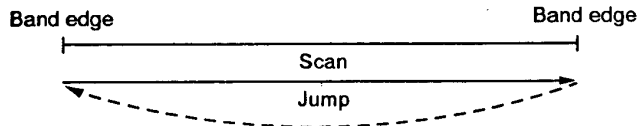

Repeatedly scans all frequencies over the entire selected band.

MEMORY SCAN

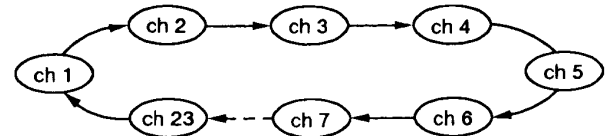

Repeatedly scans all memory channels.

PROGRAMMED SCAN

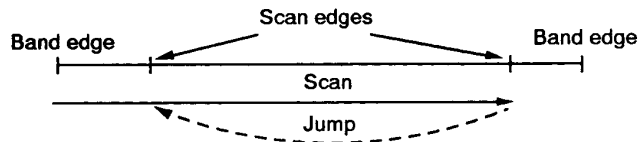

Repeatedly scans between two user-programmed frequencies. Used for checking the frequencies which allocated repeater input frequency, etc.

MEMORY SKIP SCAN

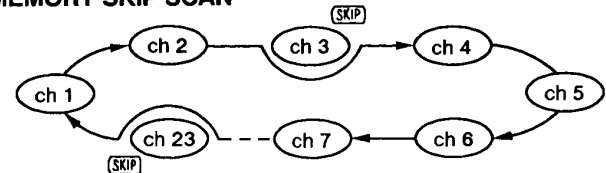

Repeatedly scans memory channels except skip channels. Used for checking the pre-programmed repeater input frequencies in unskipped memory channels, etc.

■ Scan operations

Read the following table horizontally for each type of scan; procedures in ①, ④, and ⑤ apply to all scan types.

NOTE: Each memory channel has its own squelch level setting which remains valid even while scanning. When a squelch is set to maximum (full scale), the scan might not stop on a weak signal.

SCAN TYPE	① PRE-OPERATION 1	② PRE-OPERATION 2	③ SCAN START	④ RESUME CONDITION	⑤ SCAN STOP
FULL SCAN	1) Push the desired band switch: [VHF], [UHF] or [1.2G], to select the band to be scanned.	1) Push [① V/M] to select VFO mode.	Push and hold [⊙△/SCAN] or [⊙▽/SCAN] for 1 sec.	Rotating the scanning band [DIAL] resumes the scan manually or changes the scan direction. When timer scan is selected: Scan resumes 5 sec. after receiving starts.	Push [⊙△/SCAN] or [⊙▽/SCAN]. Pushing [⊙ CLR] also stops the scan.
PRO-GRAMMED SCAN	2) Set the squelch level of the VFO to the threshold level (6 dots) or medium (10 dots). 3) Set tuning step. (p. 13)	1) Program the scan edge frequencies. (p. 27). 2) Push [① V/M] to select VFO mode.	While pushing [FUNC], push [⊙△/SCAN] or [⊙▽/SCAN].		
MEMORY SCAN	1) Push the desired band switch: [VHF], [UHF] or [1.2G], to select the band to be scanned.	Push [① V/M] to select MEMORY mode.	Push and hold [⊙△/SCAN] or [⊙▽/SCAN] for 1 sec.	When pause scan is selected: Scan resumes 2 sec. after a received signal disappears.	
MEMORY SKIP SCAN	2) Set the squelch levels of all memory channels to the threshold level (6 dots) or medium (10 dots).	1) Push [① V/M] to select MEMORY mode. 2) Set the undesired channels as skip channels. (p. 28)	While pushing [FUNC], push [⊙△/SCAN] or [⊙▽/SCAN].	Timer scan and pause scan are available. See p. 28 for details.	

11 SCAN OPERATION

■ Programming scan edges

Scan edges can be programmed in the same way as memory channels. Memory channels "A" and "b" are available for programming scan edges.

- 1) Push the desired band switch: [VHF], [UHF] or [1.2G].
- 2) Select the scan edge memory channel "A" or "b":
 - Push [① V/M] to select MEMORY mode. ("M" appears.)
 - Rotate the MAIN band [DIAL] to select the memory channel "A" or "b."
 - Memory channel "A" is next to memory channel 23.
- 3) Set the desired frequency in VFO mode:
 - Push [① V/M] to select VFO mode.
 - Rotate the MAIN band [DIAL] to set the desired frequency.
- 4) While pushing [FUNC], push and hold [① V/M].
 - If the beep tone is ON, 3 beeps alert you that the contents are programmed.
- 5) To program a frequency for the other scan edge memory channel "b" or "A," repeat steps 2-4.
 - If the same frequency is programmed into "A" and "b," programmed scan will not function.

EXAMPLE: Programming 145.30 MHz and 146.80 MHz for the scan edges.

Select VFO mode. Select memory channel "A." Set 145.30 MHz in VFO mode. Program into memory channel "A."

Select memory channel "b." Set 146.80 MHz in VFO mode. Program into memory channel "b."

■ Skip channel setting

Memory channels can be specified to be skipped for memory skip scan. This is useful to speedup the memory skip scan interval.

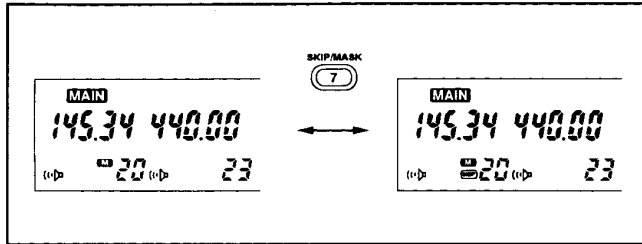

- 1) Push the desired band switch: [VHF], [UHF] or [1.2G].
- 2) Select the desired memory channel:
 - Push [①V/M] to select MEMORY mode. ("M" appears.)
 - Rotate the MAIN band [DIAL] to select the desired memory channel.
- 3) Push [⑦SKIP] to set the memory channel to the skip channel.
 - "SKIP" appears as shown above (left of center).
- 4) Repeat above steps to cancel the skip information.
 - "SKIP" disappears as shown above (far left).

■ Scan resume condition

USING SET MODE

The resume condition can be selected as a pause or timer scan. The resume condition is not only used for scan but also for priority watch.

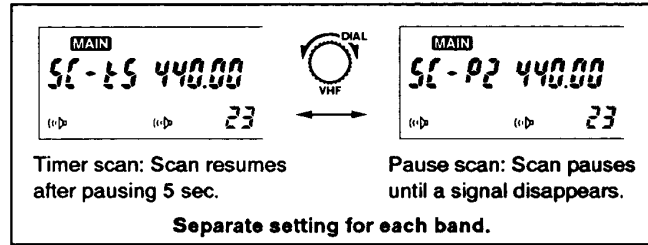

- 1) Enter SET mode:
 - Push the desired band switch: [VHF], [UHF] or [1.2G].
 - Push [①V/M] to select VFO mode if another mode has been selected.
 - While pushing [FUNC], push [⑧SET] to enter SET mode.
- 2) Push [⊙△] or [⊙▽] until "SC" appears as shown above.
- 3) Rotate the MAIN band [DIAL] to select the condition.
- 4) Push [⊗CLR] to set the condition and to exit SET mode.

12 PRIORITY WATCH

Priority watch types

Every 5 sec. priority watch monitors a selected frequency while you operate on a VFO frequency. The watch resumes according to the selected scan resume condition. See p. 28 for setting the scan resume condition. There are 2 types of priority watch as described below.

This is useful to check the pre-programmed repeater input frequency in the memory channel during operating on a VFO, etc.

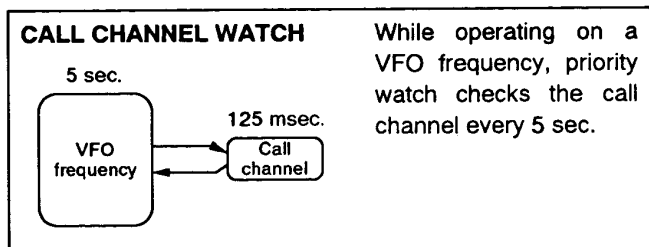
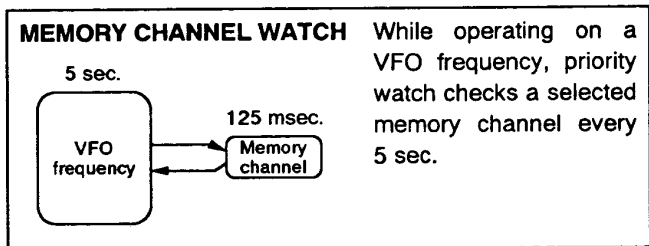

Priority watch operation

- 1) Push the desired band switch: [VHF], [UHF] or [1.2G].
- 2) Set the channel to be watched:
 - For memory channel watch, push [①V/M], then select a memory channel using the MAIN band [DIAL].
 - For call channel watch, push [④M CALL] to select the call channel.
- 3) Set the squelch to the threshold level (6 dots) or medium (10 dots).
 - When the squelch of the watching channel is set maximum (full scale), priority watch might not stop on a weak signal.
- 4) Push [PRIO] to start priority watch.
 - When receiving a signal on the selected channel, priority watch pauses for 5 sec. or until the signal disappears. See "Scan resume condition" on p. 28 for details.
 - While the watch pauses, pushing [PRIO] resumes the watch.
 - When the pager or code squelch function is in use, the priority watch cannot be activated. Turn OFF the function. (pgs. 39, 40)
- 5) Push [PRIO] while the display shows the VFO frequency to stop the priority watch.

■ Programming a DTMF code

The transceiver has 4 DTMF memory channels (a1~ a4) for storage of often-used DTMF codes of up to 15 digits. The DTMF memory channels are for common use on all bands.

- 1) While pushing [FUNC], push [DTMF M] to enter DTMF MEMORY mode.
- 2) Rotate the MAIN band [DIAL] to select the desired DTMF memory channel.
- 3) While pushing [FUNC], push [ⓈSET] to set the transceiver to the DTMF programming condition.
 - Previously programmed digits are erased.
- 4) Push the appropriate digit keys to input the DTMF code.
 - 1~0, A~D, * (E) and # (F) are available.
 - When entering a wrong digit, push [DTMF] and start again from step 3.

- 5) Push [DTMF] to store the input digits.
 - When 15 digits have been input in step 4, it is not necessary to push [DTMF].
 - When programming another DTMF memory channel, repeat steps 2~5.
- 6) Push [⊗CLR] to exit DTMF MEMORY mode.

■ Transmitting a DTMF code

- 1) Select the desired DTMF memory channel:
 - While pushing [FUNC], push [DTMF M] to enter DTMF MEMORY mode.
 - Rotate the MAIN band [DIAL] to select the desired DTMF memory channel.
 - Push [⊗CLR] to exit DTMF MEMORY mode.
- 2) While pushing [PTT], push [DTMF] to transmit a DTMF code.
 - Pushing [DTMF] without pushing [PTT] emits the DTMF code of the selected DTMF memory channel from the speaker.

EXAMPLE: Programming "1234567" into DTMF memory channel "a4."

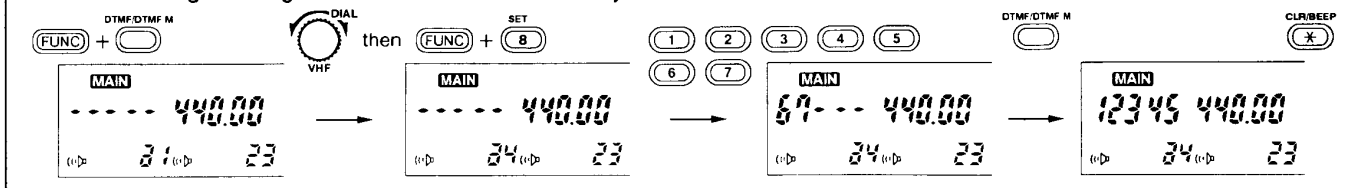

14 CLOCK AND TIMER OPERATION

Auto power-off function

The transceiver automatically turns OFF after a selected period in which no switch is pushed. This is useful if you forget to turn the power OFF.

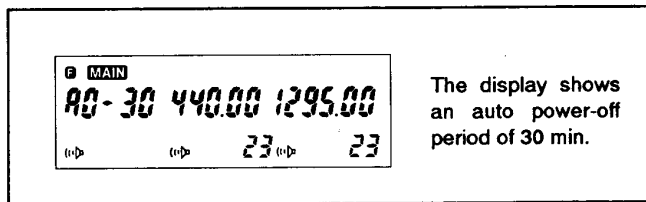

The display shows an auto power-off period of 30 min.

- 1) While pushing [FUNC], push [⊕AO] to select the auto power-off display. Continue holding [FUNC] until step 2 is completed.
- 2) While holding [FUNC], rotate the MAIN band [DIAL] to select the auto power-off period.
 - 60 min., 30 min. and OFF can be selected.
- 3) Release [FUNC] to set the value.

NOTE: The selected period is retained even after the transceiver is turned OFF by the auto power-off function. To cancel the function, select "oF" in step 2 above.

CLOCK mode

The transceiver has a built-in 24-hour clock with power-on and power-off timer functions.

The clock display can be indicated on either the 144 MHz, 430 (440) MHz or 1.2 GHz band display.

- Receiving is possible while the clock or timer display is indicated.

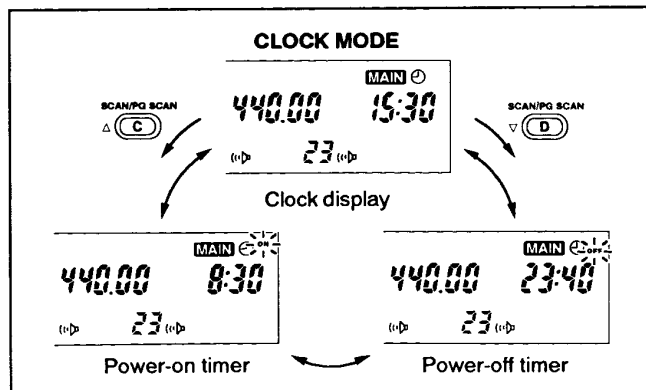
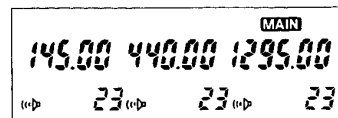

■ Clock operation

• Setting the time

- 1) Push [CLOCK] to enter CLOCK mode.
 - "⌚" appears.
- 2) While pushing [FUNC], push [SET] to set the transceiver to the time-setting condition.
- 3) Rotate the MAIN band [DIAL] to set the hour. (24-hour system)
- 4) Push [C△] or [C▽], then rotate the MAIN band [DIAL] to set the minutes.
- 5) Push [ENT] to start the clock.
- 6) Push [CLR] to exit CLOCK mode.

• Clock indication

- 1) Push [CLOCK] to call up the clock to the MAIN band.
 - Receiving is possible while the clock display is indicated.
- 2) Push [CLR] to cancel the clock indication.
 - Pushing [PTT] also cancels the clock indication when the PTT lock function is turned OFF. (p. 16)

TIME ERROR: ± 1 min./week

NOTE: CPU resetting clears the clock time. Set the time again in this case.

EXAMPLE: Setting the time for 13:45.

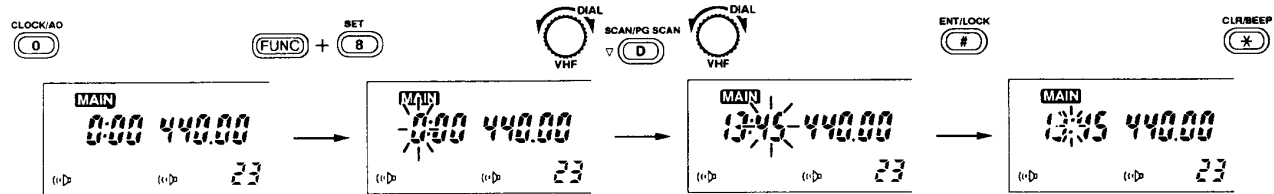

14 CLOCK AND TIMER OPERATION

■ Power-on timer

The transceiver has a power-on timer for convenience and to conserve battery power.

• Setting the power-on time

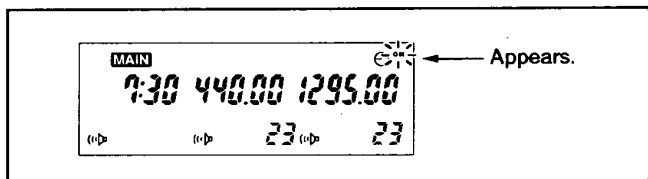

- 1) Push [CLOCK] to enter CLOCK mode.
- 2) Push [C△] to select the power-on display.
 - "⌚" appears and "ON" blinks.
- 3) While pushing [FUNC], push [7MASK] to recall the previously set time.
- 4) Set the power-on time:
 - While pushing [FUNC], push [8SET] to set the transceiver to the time-setting condition.
 - Rotate the MAIN band [DIAL] to set the hour.
 - Push [C△] or [D▽], then rotate the MAIN band [DIAL] to set the minutes.
 - Push [9ENT] to enter the time.
 - If you made a mistake, push [0CLR] and repeat step 4.

- 5) Push [0CLR] to exit CLOCK mode.

• Power-on timer operation

- 1) Set the power-on time as described at left.
- 2) Push and hold [POWER] to turn power OFF.
 - When the set time arrives, the power is automatically turned ON and 5 beeps are emitted.
 - Once power is turned ON by this timer, the power-on timer is canceled (masked), but still memorized for recalling the time.

NOTE: To cancel the power-on timer, mask the set time. Repeat steps 1~3 and 5 at left.

EXAMPLE: Setting the power-on time for 7:30.

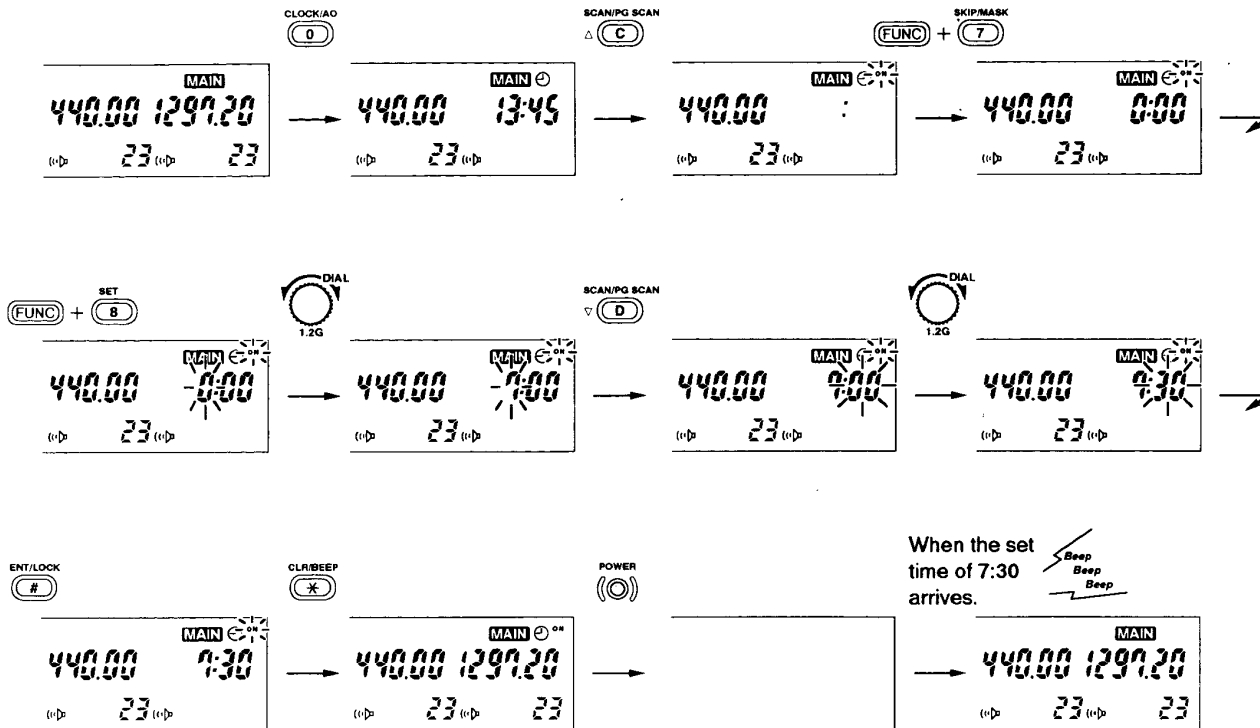

When the set time of 7:30 arrives.

Turn power OFF.

14 CLOCK AND TIMER OPERATION

■ Power-off timer

The transceiver has a power-off timer separate from the auto power-off function to turn power OFF at a preset time.

• Setting the power-off time

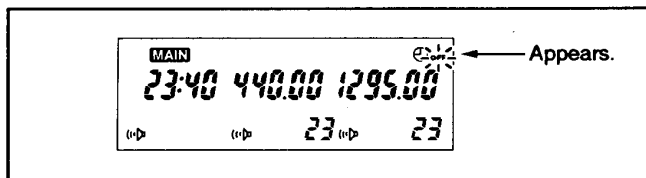

- 1) Push [ⓄCLOCK] to enter CLOCK mode.
- 2) Push [Ⓞ▽] to select the power-off display.
 - "Ⓞ" appears and "OFF" blinks.
- 3) While pushing [FUNC], push [⑦MASK] to recall the previously set time.

- 4) Set the power-off time:
 - While pushing [FUNC], push [ⓄSET] to set the transceiver to the time-setting condition.
 - Rotate the MAIN band [DIAL] to set the hour.
 - Push [Ⓞ△] or [Ⓞ▽], then rotate the MAIN band [DIAL] to set the minutes.
 - Push [ⓄENT] to enter the time.
 - If you made a mistake, push [ⓄCLR] and repeat step 4.

- 5) Push [ⓄCLR] to exit CLOCK mode.

• Power-off timer operation

- 1) Set the power-off time as described at left.
 - When the set time arrives, 5 beeps are emitted and the power is automatically turned OFF.
 - Once power is turned OFF by this timer, the power-off timer is canceled (masked), but still memorized for recalling the time.

NOTE: To cancel the power-off timer, mask the set time. Repeat steps 1-3 and 5 at left.

Incremental tuning

To compensate for the off frequency of a transmitting station, the IC-21A/E has incremental tuning for the 1.2 GHz band.

The receive incremental tuning (RIT) shifts only the receive frequency and the transmit/receive incremental tuning (VXO) shifts both the receive and transmit frequencies within approx. ± 5 kHz. When the transmitting station does not have incremental tuning (RIT, VXO or AFC), use the transmit/receive incremental tuning.

- 1) Push [1.2G] to select the 1.2 GHz band.
- 2) Select the incremental tuning type. (See at right.)
- 3) While pushing [FUNC], push [PRIO/IT] to activate the function.
 - " : " appears on the 1.2 GHz function display.
- 4) While pushing [FUNC], rotate the 1.2 GHz [DIAL] to adjust the shift frequency.
 - "dF - 7" ~ "dF 7" appears while setting the shift frequency.
 - Shift frequency steps are approx. 800 Hz.
- 5) To cancel the function, push [PRIO/IT] while pushing [FUNC]. (" : " disappears.)

Incremental tuning selection

USING SET MODE

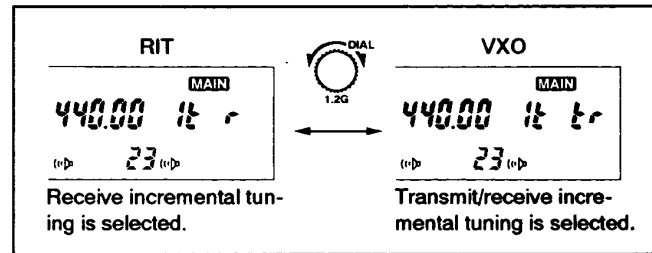

- 1) Push [1.2G] to select the 1.2 GHz band.
- 2) Enter SET mode:
 - Push [①V/M] to select VFO mode if another mode has been selected.
 - While pushing [FUNC], push [②SET] to enter SET mode.
- 3) Push [③△] or [④▽] until "It" appears as shown above.
- 4) Rotate the 1.2 GHz band [DIAL] to select the incremental tuning type; "It r" for receive incremental tuning and "It tr" for transmit/receive incremental tuning.
- 5) Push [⑤CLR] to set the condition and to exit SET mode.

16 PAGER AND CODE SQUELCH

■ General description

• Pager function

This function uses DTMF codes for paging and can be used as a "message pager" to inform you of a caller's identity even if you leave the transceiver temporarily unattended.

Personal calls and group calls are available with the pager function. Personal calls use the other station's ID code for calling. The other station's display shows your ID code and the other station knows that you called. You can also call all stations in your group using the group call.

To use the pager function in your group, all stations need the pager function.

• Code squelch

The code squelch allows you communication with silent standby since you will only receive calls from stations which know your ID or group code.

The code squelch transmits a 3-digit code prior to voice transmission in order to open the receiving station's code squelch.

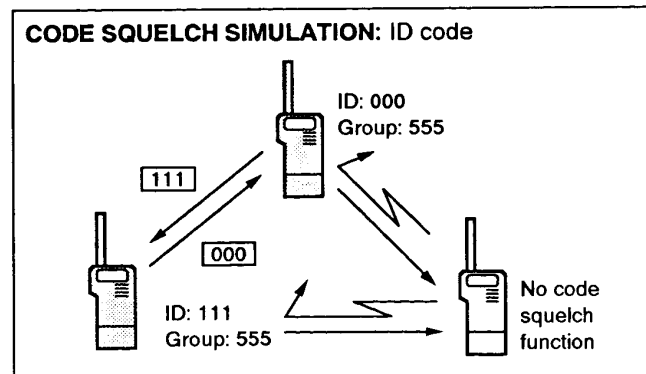
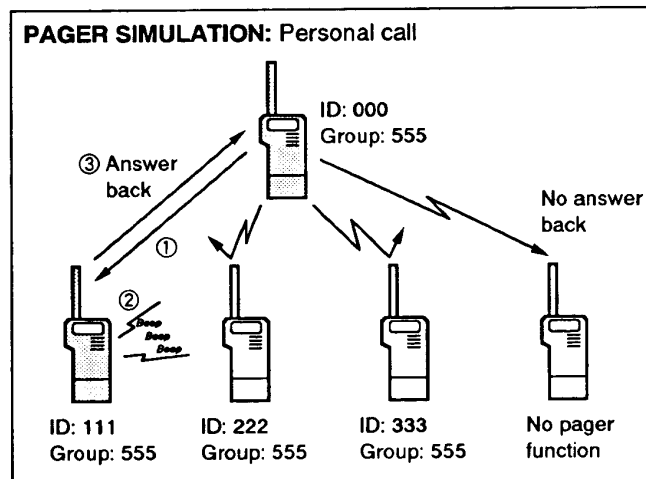

Code programming

• Before programming

The pager and code squelch functions require ID codes and a group code. These codes are 3-digit DTMF codes and must be written in the code channels before operation.

• Code channel assignment

ID OR GROUP CODE	CODE CHANNEL NUMBER	"RECEIVE ACCEPT" OR "RECEIVE INHIBIT"
Your ID code	0	"Receive accept" only.
Other station's ID code	1 ~ 5	"Receive inhibit" should be programmed in each channel.
Group code	One of 1 ~ 5	"Receive accept" must be programmed.
Memory space*	P	"Receive inhibit" only.

* Code channel P automatically memorizes an ID code when receiving a pager call. The contents in channel P cannot be changed manually.

RECEIVE INHIBIT

"Receive inhibit" channels are used only for transmitting other station's ID codes. The transceiver rejects calls when a "receive inhibit" code is sent with it. To make sure you do not receive calls directed to other stations, you should have their ID codes as "receive inhibit."

• Programming

- 1) Push the desired band switch: [VHF], [UHF] or [1.2G].
 - Each band has separate code channels.
- 2) While pushing [FUNC], push [9CODE] to select the code channel setting display.
- 3) Rotate the MAIN band [DIAL] to select the desired code channel, 0~5.
- 4) Push the numeral keys to enter the desired 3-digit code.
- 5) While pushing [FUNC], push [7SKIP] to set the channel for "receive inhibit" ("SKIP" appears) or "receive accept" ("SKIP" does not appear).
 - See the boxes at the bottom of this page for "receive inhibit" or "receive accept" details.
- 6) Push the selected band switch: [VHF], [UHF] or [1.2G], to exit the setting display.

RECEIVE ACCEPT

"Receive accept" channels are used for receiving your ID or group code. The transceiver accepts calls when a "receive accept" code is received.

■ Pager operation

• Calling a specific station

- 1) Push the desired band switch: [VHF], [UHF] or [1.2G].
 - The pager function can be used on one band only.
- 2) Set the operating frequency.
- 3) Push [Ⓢ PGR/CSQL] to turn the pager function ON.
 - "P" appears instead of the 100 MHz digit.
 - An optional tone squelch can be used together with the pager function. (p. 42)
- 4) Select the desired code channel:
 - While pushing [FUNC], push [Ⓢ CODE].
 - Rotate the MAIN band [DIAL] to select the channel.
 - Push the MAIN band switch: [VHF], [UHF] or [1.2G], to exit the setting display.
- 5) Push [PTT] to transmit the pager code.
- 6) Wait for an answer back.
 - When the transceiver receives an answer back code, the function display shows the other station's ID or group code.
- 7) After confirming a connection, push the MAIN band switch: [VHF], [UHF] or [1.2G], to display the operating frequency.

- 8) Push [Ⓢ PGR/CSQL] once to select the code squelch or twice to select the non-selective calling system.

• Waiting for a call from a specified station

- 1) Push the desired band switch: [VHF], [UHF] or [1.2G].
 - The pager function can be used on one band only.
- 2) Set the operating frequency.
- 3) Push [Ⓢ PGR/CSQL] to turn the pager function ON.
 - "P" appears instead of the 100 MHz digit.
 - An optional tone squelch can be used together with the pager function. (p. 42)
- 4) When receiving a call with a correct code, the transceiver emits a beep and the function display shows the code as shown on the page at right.
 - **DO NOT** push numeral keys while code channels 0-5 are indicated, or code channel contents are changed.
- 5) Push [PTT] to send an answer back call.
 - The display shows the operating frequency.
- 6) Push [Ⓢ PGR/CSQL] once to select the code squelch or twice to select the non-selective calling system.

PERSONAL CALL

This display appears when you are called with your ID code and the calling station's ID code is 111.

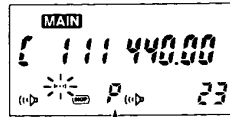

"P" appears.

GROUP CALL

This display appears when you are called with the group code, 468, and 468 has been programmed into code channel 5.

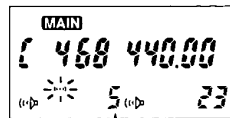

Code channel 5 appears.

ERROR INFORMATION

When the transceiver receives an incomplete signal, "E" appears.



"E" appears.

Code squelch operation

Code squelch allows communication with quiet standby since you will only receive calls from stations which know your ID or group code.

- 1) Push the desired band switch: [VHF], [UHF] or [1.2G].
 - Code squelch can be used on one band only.
- 2) Push [Ⓢ PGR/CSQL] twice to turn the code squelch ON.
 - "C" appears instead of the 100 MHz digit.
 - An optional tone squelch can be used together with the code squelch. (p. 42)

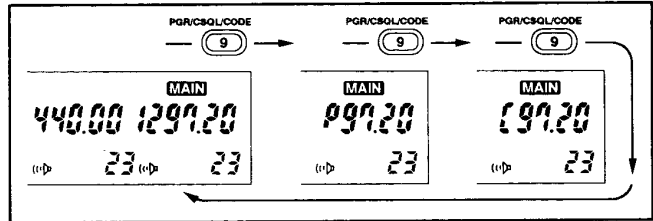

- 3) Select the desired code channel:
 - While pushing [FUNC], push [Ⓢ CODE].
 - Rotate the MAIN band [DIAL] to select the channel.
 - Push the MAIN band switch: [VHF], [UHF] or [1.2G], to exit the setting display.
- 4) Operate the transceiver in the normal way (push [PTT] to transmit; release [PTT] to receive).
 - Prior to voice transmission, a 3-digit transmit code is sent each time [PTT] is pushed in order to open the receiving station's code squelch.
- 5) To cancel the code squelch, push [Ⓢ PGR/CSQL].
 - "C" disappears.

17 OPTIONAL UNIT INSTALLATION

There are 2 types of optional internal units available.

• UT-70 TONE SQUELCH UNIT

Allows you to operate the pocket beep function or tone squelch function. (p. 42) Also allows you to operate a repeater that requires a subaudible tone* for access. (p. 17) It has simultaneous triband capability with separate subaudible tone frequencies.

• UT-71 PROGRAMMABLE TONE ENCODER UNIT

Allows you to operate a repeater that requires a subaudible tone* for access. (p. 17)

* Standard function for the U.S.A. version.

For installation, proceed as follows:

- 1) Turn power OFF, then remove the battery pack from the transceiver.
- 2) Unscrew 5 screws from the rear of the transceiver; and then, unscrew 1 screw from the top of the transceiver.
- 3) Remove the rear panel.
- 4) Plug in the optional unit as shown in the diagram at right.
 - For the U.S.A. version, replace the optional unit with the built-in TONE UNIT.
- 5) Replace the rear panel and the 6 screws.

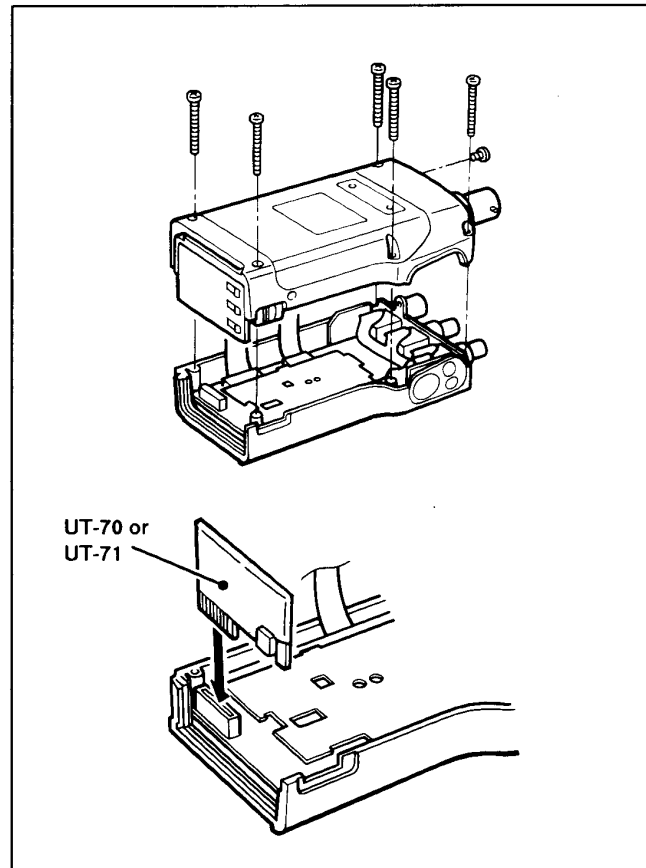

■ Pocket beep operation

This function uses subaudible tones for calling and can be used as a “common pager” to inform you that someone has called while you were away from the transceiver.

• Waiting for a call from a specific station

- 1) Program the subaudible tone frequency in SET mode.
 - See for p. 18 for programming details.
- 2) Push [Ⓢ T/TSQL/PB] several times until “[•••]” appears on the function display.
 - Turn OFF the pager or code squelch to activate the pocket beep. (pgs. 39, 40) The pocket beep cannot be used in combination with the pager or code squelch.
- 3) When a signal with the correct tone is received, the transceiver emits beep tones for 30 sec. and flashes “ [•••]. ”
- 4) Push [PTT] to answer or push the MAIN band switch: [VHF], [UHF] or [1.2G], to stop the beeps and flashing.
 - Tone squelch is automatically selected.

• Calling a waiting station using pocket beep

A subaudible tone matched with the station’s tone frequency is necessary. Use the tone squelch at right or a subaudible tone encoder (p. 17, optional for non-U.S.A. version).

■ Tone squelch operation

The tone squelch opens only when receiving a signal with the same pre-programmed subaudible tone. You can silently wait for a call from group members using the same tone.

- 1) Program the subaudible tone frequency in SET mode.
 - See for p. 18 for programming details.
- 2) Push [Ⓢ T/TSQL/PB] several times until “T SQL” appears on the function display.
 - The code squelch can be used together with the tone squelch. (p. 40)
- 3) When the received signal includes the correct tone, the squelch opens and the signal can be heard.
 - When the received signal includes an incorrect tone, the squelch does not open. Only the green indicator lights up.
 - To open the MAIN band squelch manually, push and hold [M MONI].
- 4) Operate the transceiver in the normal way (push [PTT] to transmit; release [PTT] to receive).
- 5) To cancel the tone squelch, push [Ⓢ T/TSQL/PB] several times until “T” or “T SQL” disappears from the function display.

19 TROUBLESHOOTING

■ Troubleshooting

PROBLEM	POSSIBLE CAUSE	SOLUTION	REF.
<ul style="list-style-type: none"> • No power comes on. 	<ul style="list-style-type: none"> • The battery pack is empty. • Poor plug connection at the external DC power cable. • The CPU backup battery is empty. 	<ul style="list-style-type: none"> • Charge the battery pack or place new dry cell batteries in the battery case. • Check the connector or remove the cable. • While pushing [FUNC], apply a DC power source. 	<p>pgs. 2-4</p> <p>p. 1</p>
<ul style="list-style-type: none"> • Power cannot be turned OFF. 	<ul style="list-style-type: none"> • The battery pack is empty. 	<ul style="list-style-type: none"> • Charge the battery pack or place new dry cell batteries in the battery case, then turn the power OFF. 	<p>pgs. 2-4</p>
<ul style="list-style-type: none"> • Power is turned OFF automatically. 	<ul style="list-style-type: none"> • The auto power-off function is activated. 	<ul style="list-style-type: none"> • While pushing [FUNC], push [ⓐ AO] and then rotate the MAIN band [DIAL] to turn the function OFF. 	<p>p. 31</p>
<ul style="list-style-type: none"> • No sound comes from the speaker. 	<ul style="list-style-type: none"> • A squelch is set to maximum. • Speaker select function is set for [SP2]. • An external speaker or earphone is connected. • Pager or code squelch is activated. • Pocket beep or tone squelch is activated. 	<ul style="list-style-type: none"> • Set the squelch to the threshold level. (8 dots) • Set the function for the internal speaker. • Unplug the speaker or earphone. • Push [⑨ PGR/CSQL] several times to turn the function OFF. • Push [⑥ T/TSQL/PB] several times to turn the function OFF. 	<p>p. 14</p> <p>p. 15</p> <p>pgs. 39, 40</p> <p>p. 42</p>
<ul style="list-style-type: none"> • Transmitting is impossible. 	<ul style="list-style-type: none"> • The PTT lock function is activated. • The transmit frequency is out-of-band. 	<ul style="list-style-type: none"> • While pushing [FUNC], push [③ P.L] to cancel the function. • Reset the operating frequency, offset frequency, etc. 	<p>p. 16</p> <p>p. 44</p>
<ul style="list-style-type: none"> • Frequency cannot be set. 	<ul style="list-style-type: none"> • The lock function is activated. • MEMORY mode or a call channel is selected. 	<ul style="list-style-type: none"> • While pushing [FUNC], push [Ⓢ LOCK] to turn the function OFF. • Push [① V/M] once or twice to select VFO mode. 	<p>p. 11</p> <p>p. 11</p>
<ul style="list-style-type: none"> • Scan cannot be activated. 	<ul style="list-style-type: none"> • A call channel is selected. • Priority watch is activated. • The squelch of the selected band or memory channel is set to minimum (2 dots). 	<ul style="list-style-type: none"> • Push [④ CALL] to exit the call channel. • Push [Ⓣ PRIO] to deactivate the priority watch. • Set the squelch to the threshold level (6 dots). 	<p>p. 24</p> <p>p. 29</p> <p>p. 14</p>

■ Exiting a display

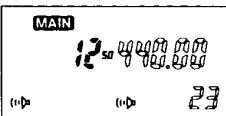

This display appears while setting the tuning step. To exit the display, push [⊕ CLR]. (p. 13)

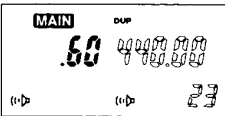

This display appears when SET mode is selected. To exit the display, push [⊕ CLR]. (p. 20)

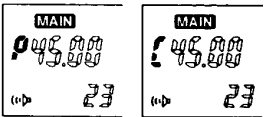

This display appears when the pager or code squelch is in use. To exit the display, push [⊙ PGR/CSQL] several times to select the non-selective calling system. (pgs. 39, 40)

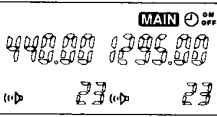

This display appears when the timer function is in use. To exit the display, mask the set time of a timer. (pgs. 33-35)

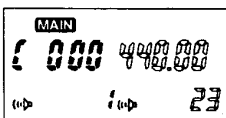

This display appears when the code channel display is selected or a pager call is received. To exit the display, push the MAIN band switch: [VHF], [UHF] or [1.2G]. (pgs. 38-40)

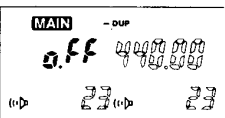

This display appears when the transmit frequency is out-of-band or off-band in semi-duplex operation. To exit the display, check and reset the operating frequency, duplex direction and offset frequency. (pgs. 17, 47)

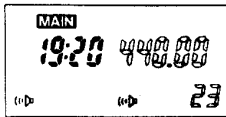

This display appears when CLOCK mode is selected. To exit the display, push the clock-displayed band switch: [VHF], [UHF] or [1.2G], and, then push [⊕ CLR]. (p. 32)

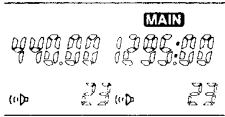

This display appears when the incremental tuning is in use. To exit the display, push [1.2G]; then, push [PRIO/IT] while pushing [FUNC] to turn OFF the incremental tuning. (p. 36)

20 OPTIONS

■ Unpacking

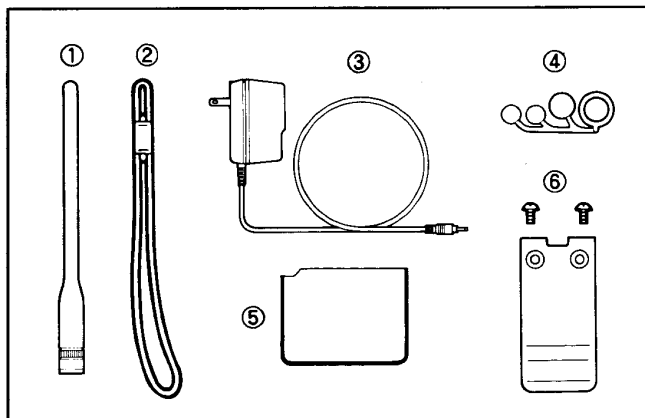

Accessories included with the transceiver:	Qty.
① Flexible antenna (FA-3BA)	1
② Handstrap	1
③ Wall charger*	1
④ Rainproof cap	1
⑤ Battery pack or case	1
⑥ Belt clip and screws	1 set

* Optional for the Asia version.

Some versions cannot use all of the following options since electrical standards, etc. vary between countries. Ask your Icom Dealer which options are available.

■ Battery packs and carrying cases

BATTERY PACK OR CASE	HEIGHT	VOLTAGE	CAPACITY	CARRYING CASE
BP-100	37 mm, 1.5 in	Battery case R6 (AA) × 6		LC-81
BP-101	43 mm, 1.7 in	7.2 V	700 mA	LC-81
BP-102	43 mm, 1.7 in	7.2 V	1200 mA	LC-81
BP-103	68.6 mm, 2.7 in	12.0 V	600 mA	LC-82

■ Other options

AD-22 BATTERY CHARGE ADAPTER

Allows you to charge the BP-101~BP-102 and NiCd batteries with BP-100 separately from the transceiver.

AD-27 BATTERY PACK ADAPTER

Used with BC-79 to charge the battery packs for the IC-21A/E.

BC-77A/E/D/V WALL CHARGER

Charges the BP-101~BP-103. NiCd batteries with BP-100 can be also charged.

BC-79 DESKTOP CHARGER

Rapidly charges the BP-101~BP-103 with an optional AD-27. Both AC and DC can be used as a power supply.

CP-13 CIGARETTE LIGHTER CABLE WITH NOISE FILTER

For operating the transceiver or charging a battery pack through a 12 V cigarette lighter socket.

HM-65 SPEAKER-MICROPHONE

Combination speaker-microphone with an earphone jack. Alligator clip facilitates carrying. Only the speaker-selected band audio can be heard. (p. 15)

HM-70 SPEAKER-MICROPHONE

Combination speaker-microphone. A large speaker provides louder audio reception. Alligator clip facilitates carrying. Only the speaker-selected band audio can be heard. (p. 15)

HS-60 HEADSET

Includes a VOX and one-touch PTT functions. Two earphones allow separate band receiving with the speaker select function. (p. 15)

MB-24 MOUNTING BRACKET (Hanger-type)

Transceiver bracket for mobile operation.

MB-25 MOUNTING BRACKET (Wall-type)

Mounting bracket for mounting the transceiver to a wall, etc.

OPC-288 DC POWER CABLE

For operating the transceiver or charging a battery pack with a 12.5 V external power supply.

UT-70 TONE SQUELCH UNIT

Provides a "personalized" tone squelch system with other stations. Has simultaneous triband capability with separate subaudible tone frequencies. Also functions as a programmable tone encoder.

UT-71 PROGRAMMABLE TONE ENCODER UNIT

Allows you to operate a repeater that requires a subaudible tone. Built-in to the U.S.A. version.

21 SPECIFICATIONS

General

- Frequency coverage :

VERSION	144 MHz	430 (440) MHz	1.2 GHz
U.S.A.	T: 144~148 MHz	440~450 MHz	1240~1300 MHz
	R: 138~174 MHz ^{*1}		
Asia	T: 144~148 MHz	430~440 MHz	1240~1300 MHz
	R: 138~174 MHz ^{*1}		
Australia	144~148 MHz	430~440 MHz	1240~1300 MHz
Europe	144~146 MHz	430~440 MHz	1240~1300 MHz
Italy	T: 144~148 MHz	430~440 MHz	1240~1300 MHz
	R: 138~174 MHz ^{*1}		

^{*1} Guaranteed frequency coverage is 144~148 MHz.

- Mode : FM
- Frequency stability
(0 °C ~ + 50 °C ; + 32 °F ~ + 122 °F):
 144 MHz/430 (440) MHz ± 5 ppm
 1.2 GHz ± 3 ppm
- Antenna impedance : 50 Ω (nominal)
- Usable temperature range: - 10 °C ~ + 60 °C ;
 + 14 °F ~ + 140 °F
- Tuning steps :
 144 MHz/430 (440) MHz 5, 10, 12.5, 15, 20, 25, 30 and
 50 kHz
 1.2 GHz 10, 20, 25 and 50 kHz
- Dial select steps : 100 kHz, 1 MHz and 10 MHz^{*2}
^{*2} 1.2 GHz band only

- Number of memory : 78 (Scan edge and call channels channels included.)
- Usable battery pack : BP-100~BP-103 or case
- External DC power supply : 6~15 V DC (negative ground)
- Current drain (typical) :

CONDITION		144 MHz	430 (440) MHz	1.2 GHz
Transmit (13.5 V)	High	1.9 A	1.9 A	1.1 A
	Low 1	700 mA	700 mA	700 mA
Receive (12.5 V)	Power saved	20 mA ^{*3}	24 mA ^{*3}	24 mA ^{*3}
	Rated audio output	180 mA	200 mA	210 mA

^{*3} Average value

- Dimensions (projections not included):
 with BP-102 58(W) × 145(H) × 49(D) mm
 2.3(W) × 5.7(H) × 1.9(D) in
 with BP-100 58(W) × 139(H) × 49(D) mm
 2.3(W) × 5.5(H) × 1.9(D) in
- Weight :
 with BP-102 635 g; 1.4 lb
 with BP-100 585 g; 1.3 lb (6 dry cell batteries are included. Weight varies depending on the battery type.)

Transmitter

- Output power** (at 13.5 V DC):

144 MHz/430 (440) MHz	5.0 W, 3.5 W, 1.5 W and 500 mW selectable
1.2 GHz	1.0 W and 200 mW selectable
- Modulation system : Variable reactance frequency modulation
- Max. frequency deviation**: ± 5.0 kHz
- Spurious emissions** :

144 MHz/430 (440) MHz	Less than -60 dB
1.2 GHz	Less than -40 dB
- Microphone impedance : $2\text{ k}\Omega$

Receiver

- Receive system : Double-conversion superheterodyne
- Intermediate frequencies :

144 MHz	1st 30.85 MHz	2nd 455 kHz
430 (440) MHz	1st 35.8 MHz	2nd 455 kHz
1.2 GHz	1st 72.2 MHz	2nd 455 kHz
- Sensitivity** (for 12 dB SINAD):

144 MHz/430 (440) MHz	Less than $0.16\ \mu\text{V}$
1.2 GHz	Less than $0.2\ \mu\text{V}$
- Squelch sensitivity (at threshold, typical):

144 MHz/430 (440) MHz	Less than $0.125\ \mu\text{V}$
1.2 GHz	Less than $0.16\ \mu\text{V}$
- Selectivity : More than $15\text{ kHz}/-6\text{ dB}$
Less than $30\text{ kHz}/-60\text{ dB}$
- Spurious response rejection ratio** (except 1/2 intermediate frequency):

144 MHz/430 (440) MHz	More than 60 dB
1.2 GHz	More than 50 dB
- Audio output power** : More than 200 mW at 10% distortion with an $8\ \Omega$ load.
- Audio output impedance : $8\ \Omega$

All stated specifications are subject to change without notice or obligation.

** Specifications guaranteed at a transceiver temperature of $25\text{ }^\circ\text{C}$ ($+77\text{ }^\circ\text{F}$).

Count on us!

A-5207S-1EX
Printed in Japan
Copyright © 1992 by Icom Inc.

Icom Inc.
6-9-16, Kamihigashi, Hirano-ku, Osaka 547, Japan